

**Anhui Risesat Electronics Co., LTD**

**DC24V Heavy Duty  
Swing Gate Opener Manual**

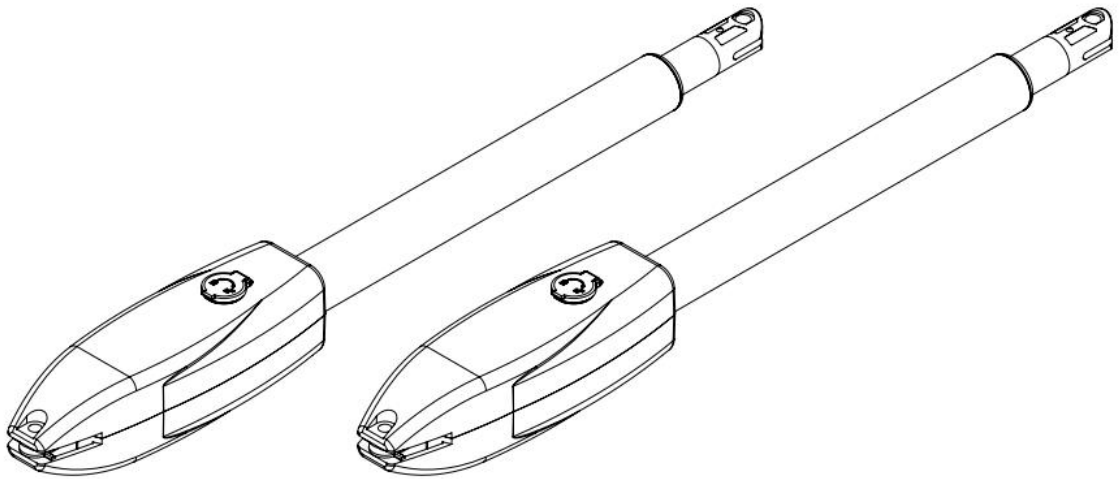

**Attention**

The manual should be read cover  
to cover once prior to beginning installation

# Anhui Risesat Electronics Co., LTD

## CAUTION:

- This product must be installed by well-trained skilled personnel in compliance with the safety regulations the field of residential and commercial swing gate opener devices. Unqualified personnel may damage the instruments And cause harm to the public.
- Electric Power must be disconnected prior to installation, or performing any maintenance.
- Please read the manual carefully before installation. Incorrect installation or misuse of product may cause seriously damage to users and property.
- If the electric cable is damaged or broken, it must be replaced by a whole and properly insulated wires, to avoid electric shock or any hazardous environments.
- Keep the wireless transmitters out of children reach.
- Do not allow children or other individuals to stand by the path of the motor arms or the path of the gates while in operation.
- Do not use the remote wireless transmitters when the gates are out of sight.
- Do not install the products in corrosive, inflammable, and/or explosive environments.
- Avoid installing the motor arm where the override manual release key is exposed to the public .

## Tools Required

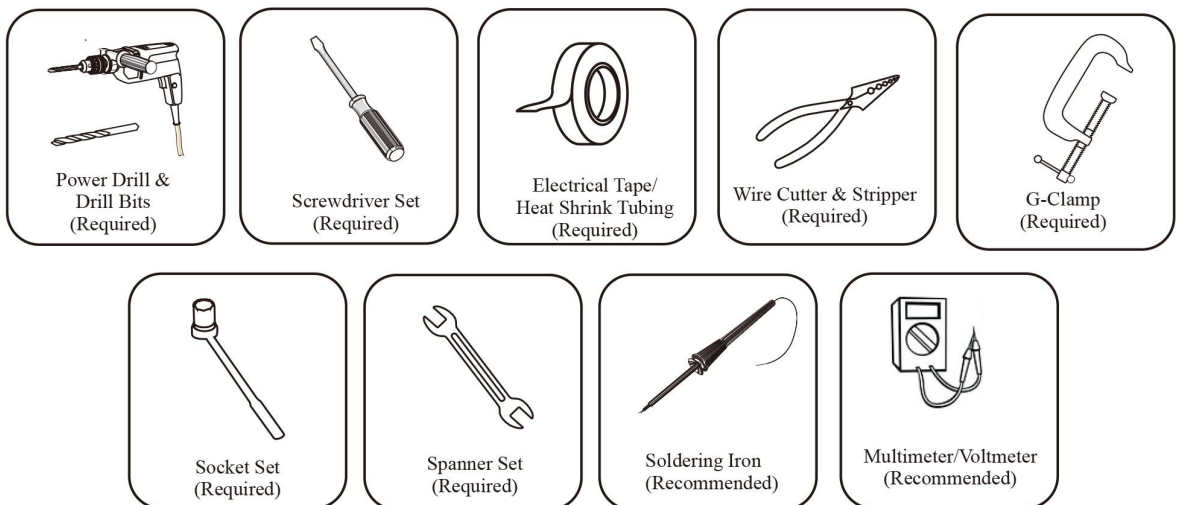

# Anhui Risesat Electronics Co., LTD

## I. Products Configurations:

### Products and accessories list



Figure 1

# Anhui Risesat Electronics Co., LTD

## Nomenclature of Swing Gate Motor

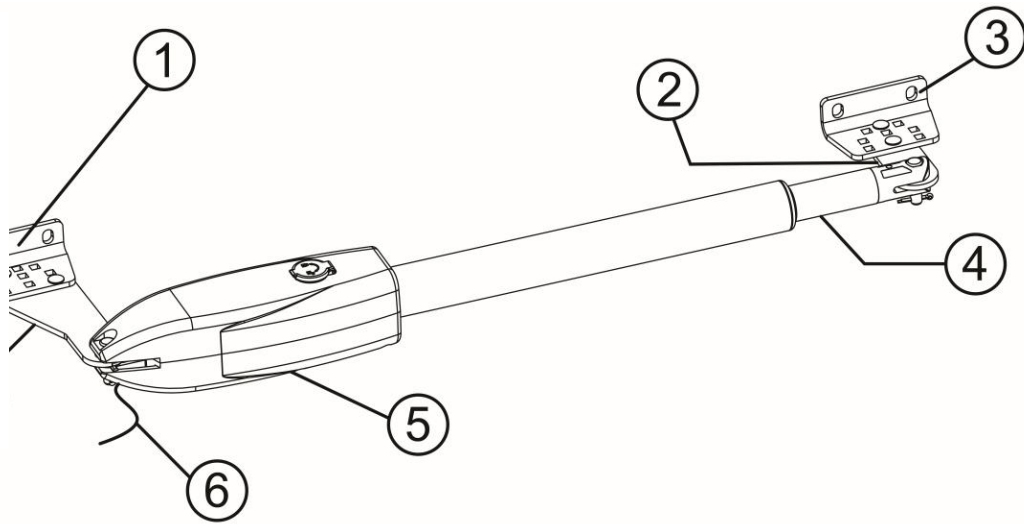

**FIGURE 2**

- Item 1:** Post Rear Fixed Bracket
- Item 2:** Extended Bracket Attached to Gate Structure
- Item 3:** Gate Front Fixed Bracket
- Item 4:** 300-400mm Extended Arm
- Item 5:** Motor Gear Box
- Item 6:** Power Cable
- Item 7:** Rear Bracket Fixed Plate Main Motor Arm

## Override Manual Release Key



**Figure 3**

## II. Swing Gate Opener Features & Options:

1. **In case of power failure:** Use the manual override key to release the clutch to open or close the gate manually.

# Anhui Risesat Electronics Co., LTD

2. **When Gate is Obstructed:** Gate stops .
3. **Optional:** The Gate Opener Controller can be connected to a solar system, a flash light warning, a photocell, back up battery, keypad and other access control devices.
4. **Speed Control:** Gate opening and closing speed can be adjusted.
5. **Gentle Start:** The Gate Opener is equipped with a soft start function.
6. **Auto Close:** The Gate Opener System is equipped with Auto close function with adjustable closing time delay.
7. **Single or Dual Gate:** Either Single or Dual Swing Gate can be opened.
8. **Multiple Remote Transmitters:** The Controller can easily accommodate several unique extra remotes to control the swing gate opener
9. **Battery Back Up:** DC 24V back up battery can be incorporated
10. **Optional Devices:** DC 24V Gate Lock ,photocell ,keypad , photocell,push button, large size or small size control box.
11. The Gate Opener can be configured to allow smooth noiseless operation.
12. The Gate Opener can be configured to enable open condition as default, or close condition as default depending on the placement of the provided hardware bracket brackets.

## III. Technical Specifications

<b>Motor voltage:</b> 24VDC 60W	<b>Input power:</b> 220VAC ± 10%/120VAC ± 10%
<b>Rotational speed:</b> 300 RPM	<b>Arm's extended speed:</b> 2.4 cm/s
<b>Arm's max travel:</b> 400 mm	<b>Continue running time:</b> 5 minutes
<b>Max single-leaf length:</b> 3.5meters	<b>Max single-leaf weight:</b> 350KG
<b>Environment Temperature:</b> -20°C ~ +50°C	<b>Protection Class:</b> IP55
<b>Max gate open angle:</b> 110 degree	<b>Dual Swing Gate Gross weight :</b> 17.5kg

## IV. Preparing The Installation Site:

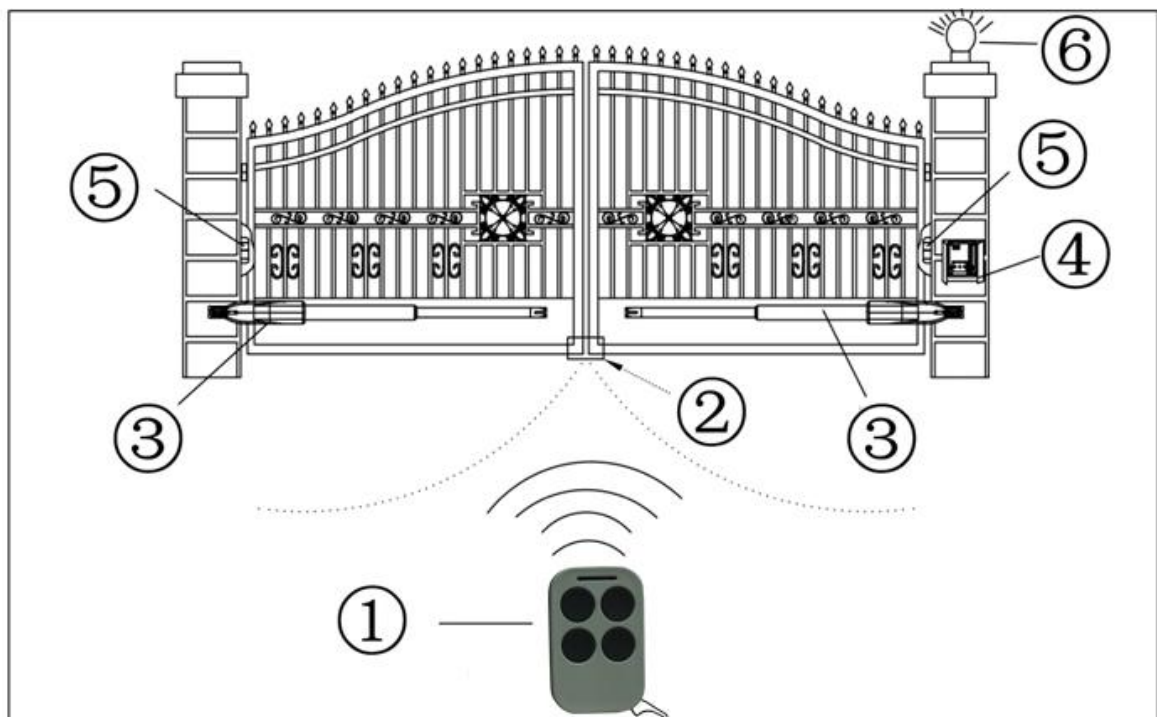

# Anhui Risesat Electronics Co., LTD

## Item Nomenclature

- |                            |                                   |
|----------------------------|-----------------------------------|
| 1. Wireless Transmitter    | 4. Control Box                    |
| 2. Rubber Stopper          | 5. Photocell Electric Sensor      |
| 3. Swing Gate Opener Motor | 6. Flash Light Alarm ( Optional ) |

## V. Rear Bracket Installation Alternatives to Gate Posts

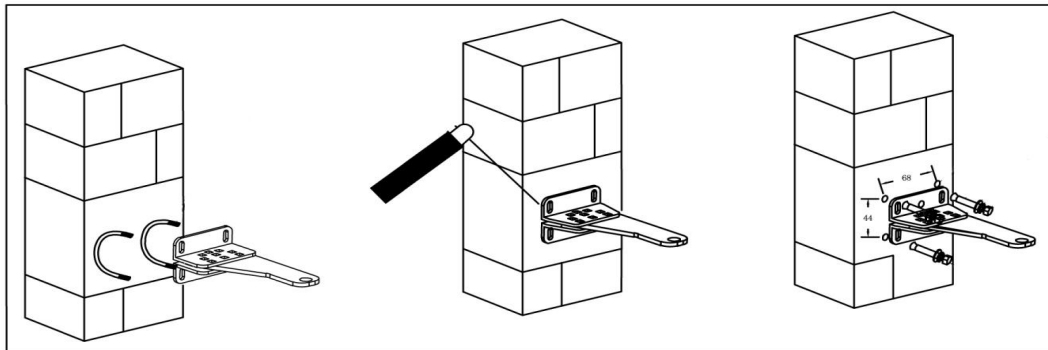

Figure 5

### 2. Construction Drill and Weld, Figure 5 middle:

- Drill 4 Holes of 8mm Diameter
- Locate the 4 Slotted Holes Post Bracket above the Drilled Holes
- Weld the Motor Bracket to the Post Bracket

### 3. Precast U Bolts, Figure 5 left:

- Locate the 4 Slotted Holes of the Post Bracket above the End of U Bolts
- Apply the Appropriate Screws
- Place the Motor Connecting Bracket and Tighten with the Provided Screws

### 4. Adjusting different angles of Rear Bracket Fixed Plate to fit different

Installing condition .

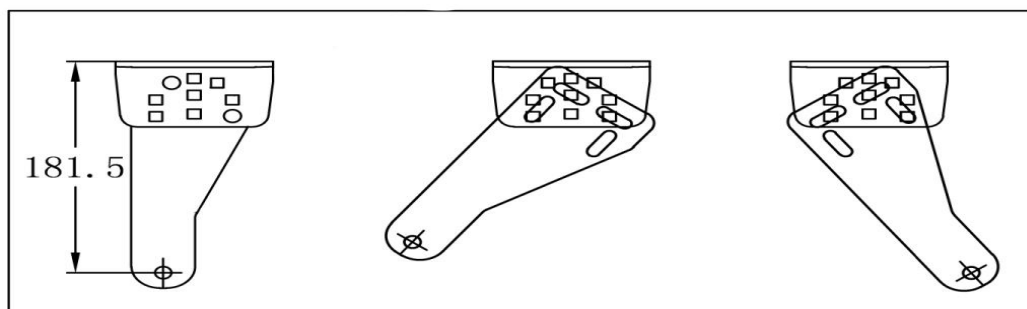

Figure 6

# Anhui Risesat Electronics Co., LTD

## VI. Install the Motor Fixed-End to the Gate Post-Bracket

1. Ensure the Override Motor Key Post to face the ground away from the view of the public.

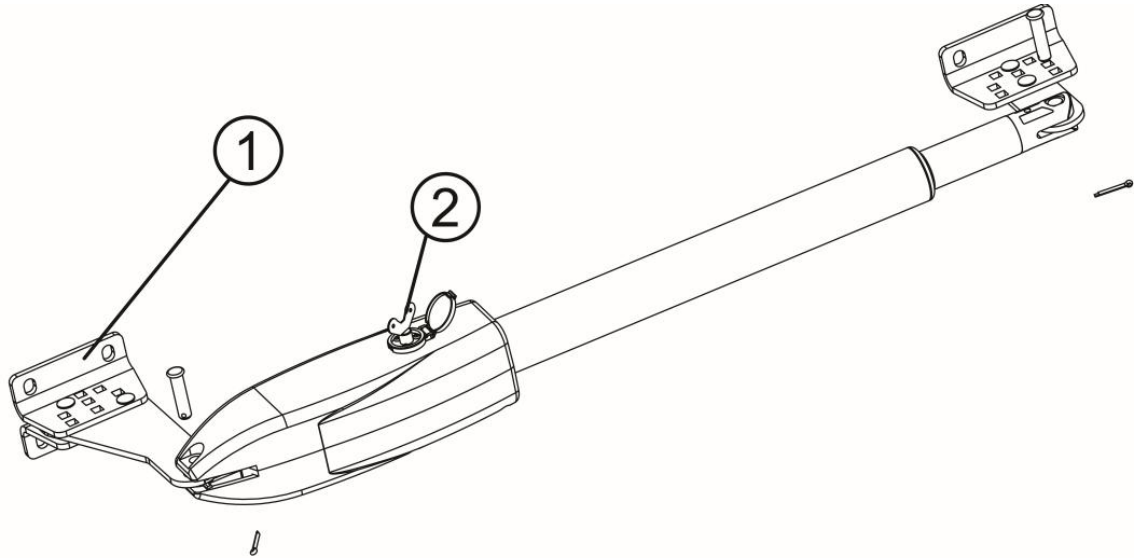

Figure 7

2. Once the Lock Pin and the Lock Washer are inserted between the Fixed End Motor and the Gate Post Bracket insure the power is not connected
3. Insert Override Manual Key
4. Turn the Key Clockwise to disengage the motor clutch to enable manual operation of gate.

## VII. Considerations

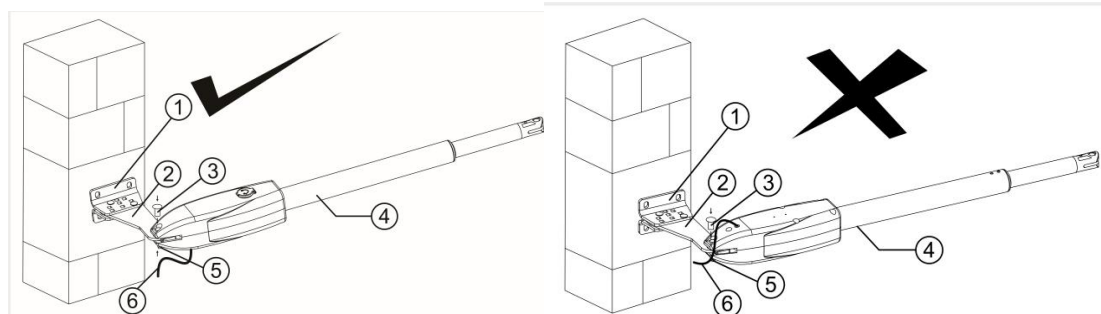

Figure 8

### Figure 8 left, Power Cable And Manual Override Release Placed Correctly

- 1 Post Rear Fixed Bracket
- 2 Rear Bracket Fixed Plate Main Motor Arm

### Figure 8 right, Power Cable And Manual Override Release Placed Incorrectly

- 4 Rain Drainage Aperture
- 5 Washers and Lock Nuts

# Anhui Risesat Electronics Co., LTD

## 3 Lock Pin

## 6 Power Cable

### Notice : Incorrect Installation, Figure 8 right:

Cable must not be installed above the motor arm. It may pinch and strip the cable and causes electric shock. Also the manual override release must be located face to the ground. Follow correct installation as shown in Figure 8 left.

### VIII. Installation of Extended or Retracted End Motor Arms to Gates:

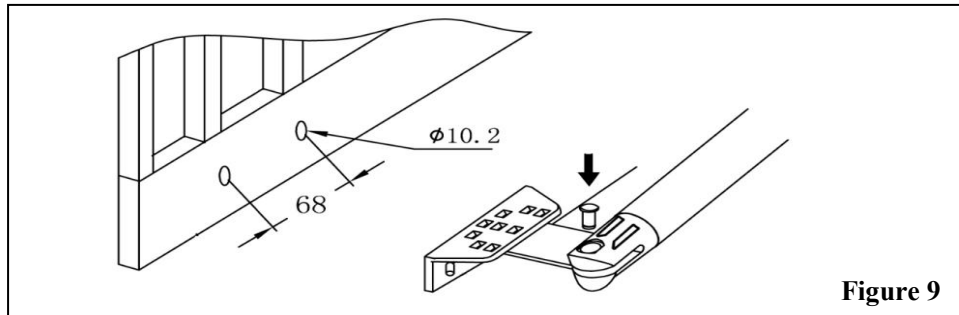

- A. Drill 2 Holes of 10.2mm Diameter With Space 68mm Between 2 Holes
- B. Locate the 2 Slotted Holes Gate Bracket above the Drilled Holes
- C. Place the End Motor Bracket to the Gate Bracket using the Appropriate Bolts and Tighten Properly(Please note these bolts used to fixed front bracket to the gate are not provided due to the thickness of each gate is different)
- D. Insert the Lock Pin and Clamping Washers

### Brackets Height :

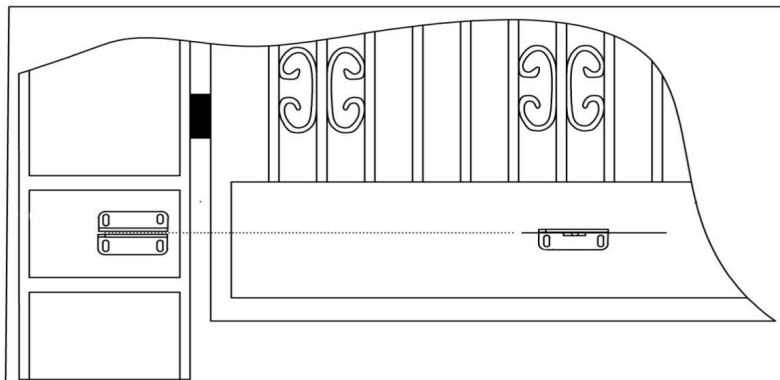

Figure 10

**Ensure that the Post bracket height is in the same exact level with the gate bracket height. Failing to ensure accurate common heights will cause the motor arm to bend leading to failure. Also, the force to push or pull the gate will be reduced causing the motor to open or close the gates with difficulty or may not operate successfully at all. Severe different in height will damage the motor and**



# Anhui Risesat Electronics Co., LTD

the motor arm.

## Configuration of Normally Closed Gate Opener System

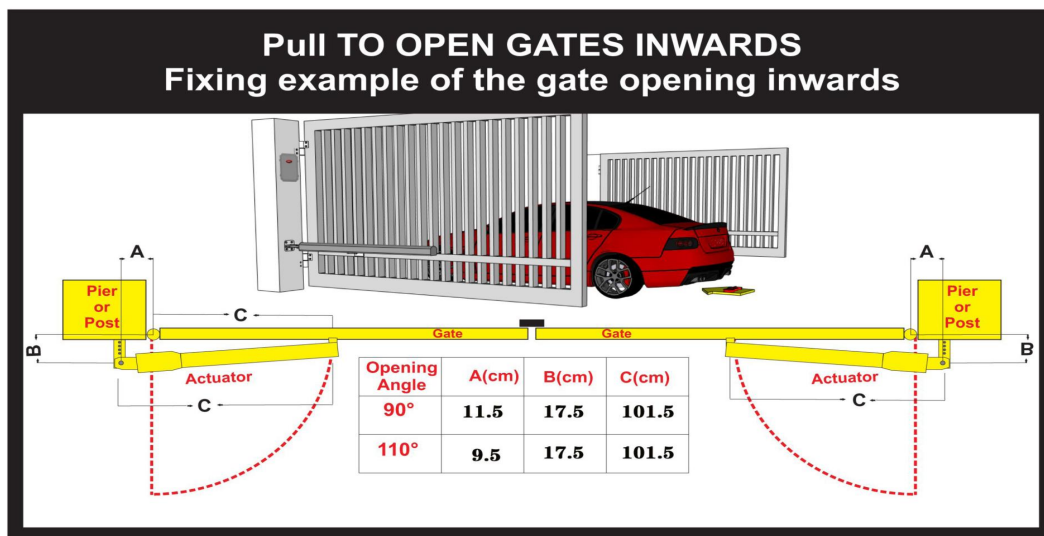

Figure 11

- A: The Distance between the Gate Post Edge and the Fixed Motor Hinge
- B: The Distance between the Gate Hinge and the Centerline of the Motor Hinge
- C: The Distance between the Gate Hinge and the Maximum Distance of the Retracted Motor Condition

## Configuration of Normally Open Gate Opener System

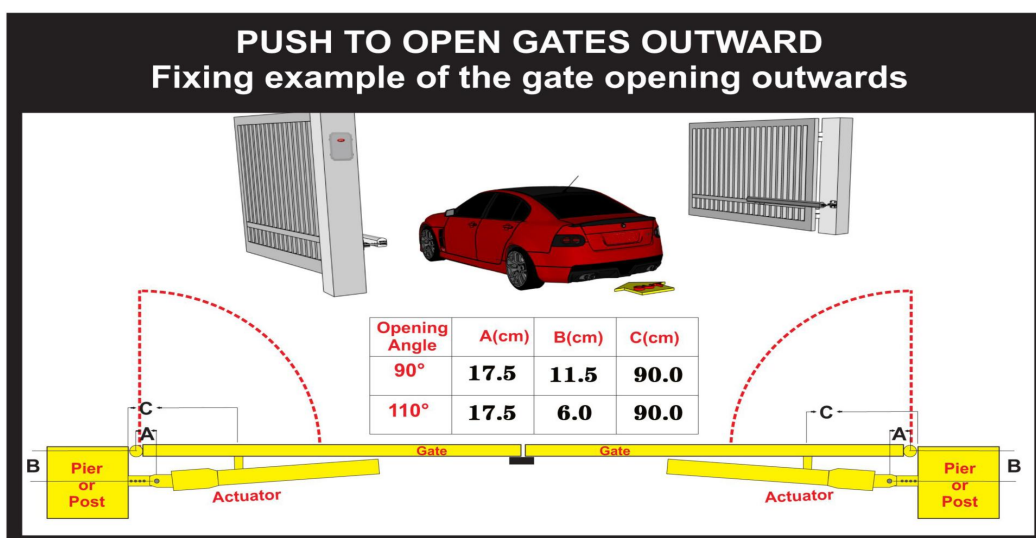

Figure 12

# Anhui Risesat Electronics Co., LTD

- A:** The Distance between the Gate Post Edge and the Fixed Motor Hinge
- B:** The Distance between the Gate Hinge and the Centerline of the Motor Hinge
- C:** The Distance between the Gate Hinge and the Maximum Distance of the Retracted Motor Condition

## **Control board wiring diagram:**

### **Technical Parameters:**

1. Control Panel Voltage: AC24V, available for 24 V back up battery.
2. Applicable Range: Suitable for double arms swing gate opener.
3. Encoder For transmitter: Our own customized rolling code.
4. Support remote control: Can memorize 120PCS transmitters at most
5. Motor character: 24V DC motor x2

# Anhui Risesat Electronics Co., LTD

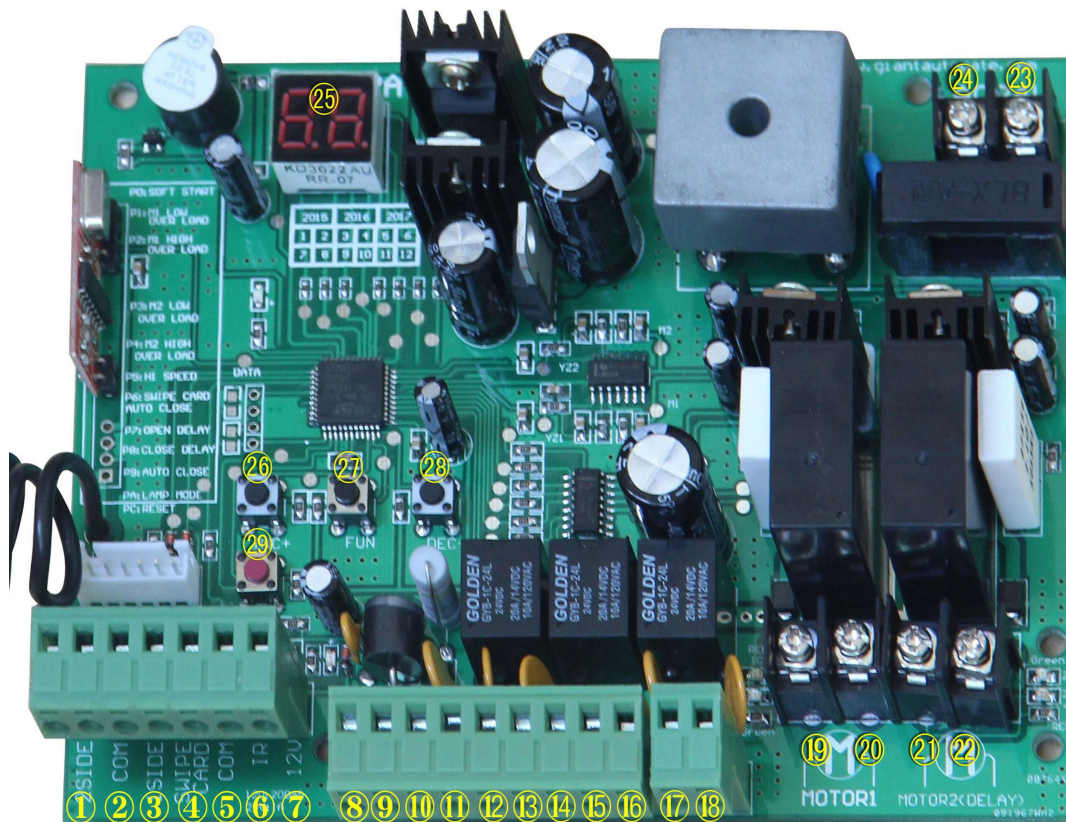

1. 2 SIDE terminal is used for connecting any external device that operates double gate
2. COM terminal is COMMON used for connecting the “ground” of external devices
3. 1 SIDE terminal is used for connecting any external device that operates single gate
4. Swipe Card terminal is used for connecting any external devices that will operate to open the gate
5. COM terminal is COMMON used for connecting the “ground” of external devices
6. Infrared terminal is used for connecting photo electric sensor
7. 12V DC output is used for connecting photo electric sensor (Continuous output current  $\leq 200\text{mA}$ )
8. 24V battery output is used for connecting the back up battery +
9. 24V battery output is used for connecting the back up battery -
10. 24V DC output is used for connecting external device. (such as photo electric sensor, max current output 1A)
11. GND is used for connecting the “ground” of external devices
12. 24V DC lamp output is used for connecting flash light +.
13. 24V DC lamp output is used for connecting flash light -.
14. 24V DC lock output—the NF terminal which used for connecting the electromechanical lock
15. COM is COMMON used for connecting the “ground” of lock
16. 24V DC lock output—the NA terminal which used for connecting the magnetic lock
17. 24V DC alarm output
18. 24V DC alarm output

# Anhui Risesat Electronics Co., LTD

19. Motor1 terminal is used for connecting the motor 1 installed on the gate that opens later and close first. This terminal connect 1<sup>st</sup> red wire (counted from your left hand side to right hand side)
20. Motor1 terminal is used for connecting the motor 1 installed on the gate that opens later and close first. This terminal connect 2<sup>nd</sup> blue wire (counted from your left hand side to right hand side)
21. Motor2 Delay terminal is used for connecting the motor 2 installed on the gate that opens first and close later. This terminal connect 1<sup>st</sup> blue wire (counted from your left hand side to right hand side). NOTE! If for single gate, the gate motor just can connect the Motor2 Delay terminal.
22. Motor2 Delay terminal is used for connecting the motor 2 installed on the gate that opens first and close later. This terminal connect 2<sup>nd</sup> red wire (counted from your left hand side to right hand side).
23. AC24V input is used for connecting the transformer
24. AC24V input is used for connecting the transformer
25. digital display is used for showing you the setting data
26. INC+ is used for figure increase when setting the data
27. FUN is used for store the data
28. DEC- is used for figure decrease when setting the data
29. Learning button is used for program/remove remote

## Remote control

Button “1” depressed to operate single gate; button “2” depressed to operate double gate; button “3” depressed for alarm output

Program new remote control:

First step:

Press the LEARN button on the control board for about 1 second, the indicator LED would turn off, then now means have already enter learning

Second step:

Press any button of the new remote control for about 2 second, then digital display would show the remote number while indicator LED on board starts flash four times with one buzzer sound then now means the learning successfully.

Note! After you press LEARN button, if not receive the new remote signal within 5s, indicator LED would turn on and exit learning.

Remove remote control:

Press and hold the LEARN button for about 5 second, if with one buzzer sound and indicator LED light on, then now means remove remote successfully.

## Setting of the control board:

After power on, digital display will self-check from 00-99 with buzzer sound. If indicator LED light on, buzzer stop sound, it means the system is normal.

Basic operation method:

Press and hold the [ FUN ] button until the digital display shows PO. Now you enter the menu

[www.risesat.com](http://www.risesat.com)

# Anhui Risesat Electronics Co., LTD

setting. You could through adjust the [INC+] [DEC-] to increase or decrease the serial number or numerical value. After data adjust well then press [ FUN] to store the data. With one sound of buzzer, the store successfully. After store the data, the digital display would still on the menu number you just set, if you need to enter next menu setting, please press [INC+] or [DEC-] to choose and confirm with [FUN] to enter the menu number you want to set. Such as after you store the P0 value and press [FUN] to store it, then now the digital display would still show the number P0, and if you want go further to adjust P1, please press one [INC+], then digital display show P1, later press [FUN] to enter the P1 setting. And if you not need to enter next menu setting, you could press [LEARN] button to exit the menu setting.

## 1. To set the soft start time:

When digital display indicate P0, the gate opener is on the soft start time setting. The soft start time adjustable from 0-6s, 0s means close the soft start time, max soft start time 6s. Each time you press and release the [INC+] button, the figure increase by 1; each time you press and release the [DEC-] button, the figure decrease by 1. Press the [FUN] button to store the data when the soft start time chosen, then the soft start time setting finished (Factory set 2s).

## 2. To set the level of stall force:

2a-- When digital display indicate P1, the gate opener is on Motor 1 low speed running stall force adjustment. There is 0-20 levels for optional, each time you press and release the [INC+] button, the figure increase by 1; each time you press and release the [DEC-] button, the figure decrease by 1. Press the [FUN] button to store the data when the stall force level chosen, then the stall force of Motor 1 low speed running stall force adjustment finished. (factory set 6 level)

2b-- When digital display indicate P2, the gate opener is on Motor 1 high speed running stall force adjustment. There is 0-20 levels for optional. Each time you press and release the [INC+] button, the figure increase by 1; each time you press and release the [DEC-] button, the figure decrease by 1. Press the [FUN] button to store the data when the stall force level chosen, then the stall force of Motor 1 high speed running stall force adjustment finished. (factory set 10 level)

2c-- When digital display indicate P3, the gate opener is on Motor 2 low speed running stall force adjustment. There is 0-20 levels for optional. Each time you press and release the [INC+] button, the figure increase by 1; each time you press and release the [DEC-] button, the figure decrease by 1. Press the [FUN] button to store the data when the stall force level chosen, then the stall force of Motor 2 low speed running stall force adjustment finished. (factory set 6 level)

2d-- When digital display indicate P4, the gate opener is on Motor 2 high speed running stall force adjustment. There is 0-20 levels for optional. Each time you press and release the [INC+] button, the figure increase by 1; each time you press and release the [DEC-] button, the figure decrease by 1. Press the [FUN] button to store the data when the stall force level chosen, then the stall force of Motor 2 high speed running stall force adjustment finished. (factory set 10 level)

## 3. To set the high speed running time:

When digital display indicate P5, the gate opener is on high speed running time setting. There is 0-33s for optional. 0s means without high speed running, gate opener would keep running in slow speed. Max high speed running time 33s. Each time you press and release the [INC+] button, the figure increase by 1; each time you press and release the [DEC-] button, the figure decrease by 1. Press the [FUN] button to store the data when the high speed running time chosen, then the high

# Anhui Risesat Electronics Co., LTD

speed running time setting finished. (factory set 5s)

## 4. To set the auto close time after swipe card:

When digital display indicate P6, the gate opener is on auto close time setting ( NOTE! this auto close time just means the auto close function which realize through external device-). There is 0-99s for optional. 0 means the gate opener would not auto close after swipe card. Max auto close time after swipe card 99s. Each time you press and release the [INC+] button, the figure increase by 1; each time you press and release the [DEC-] button, the figure decrease by 1. Press the [FUN] button to store the data when the auto close time after swipe card chosen, then the auto close time after swipe card finished. (factory set 10s)

## 5. To set the interval time:

5a. When digital display indicate P7, the gate opener is on open interval time setting. There is 0-10s for optional. 0s means double gates open simultaneously. "1" means the Motor 2 start to open 1 second before Motor 1 start to open. Max open interval time 10s. Each time you press and release the [INC+] button, the figure increase by 1; each time you press and release the [DEC-] button, the figure decrease by 1. Press the [FUN] button to store the data when the open interval time chosen, then the open interval time setting finished. (factory set 0s)

5b. When digital display indicate P8, the gate opener is on close interval time setting. There is 0-10s for optional. 0s mean double gates close simultaneously. "1" means the Motor 1 start to close 1 second before Motor 2 start to close. Max close interval time 10s. Each time you press and release the [INC+] button, the figure increase by 1; each time you press and release the [DEC-] button, the figure decrease by 1. Press the [FUN] button to store the data when the close interval time chosen, then the close interval time setting finished. (factory set 0s)

## 6. To set auto close time:

When digital display indicate P9, the gate opener is on auto close time setting. There is 0-99s for optional. 0s mean the gate opener would not auto close. Max auto close time is 99s. Each time you press and release the [INC+] button, the figure increase by 1; each time you press and release the [DEC-] button, the figure decrease by 1. Press the [FUN] button to store the data when the auto close time chosen, then the auto close time setting finished. (factory set 0)

## 7. To set lamp/alarm output control:

When digital display indicate PA, the gate opener is on lamp/alarm output control setting. There is 0-3 for optional. "0" means the alarm on monostability model and the lamp without voltage output after the gate total close 30s, other time with voltage output. "1" means the alarm on monostability model and the lamp would only flash when gate running. "2" means the alarm on bistability model and the lamp without voltage output after the gate total close 30s, other time with voltage output. "3" means the alarm on bistability model and the lamp would only flash when gate running. Each time you press and release the [INC+] button, the figure increase by 1; each time you press and release the [DEC-] button, the figure decrease by 1. Press the [FUN] button to store the data when the auto close time chosen, then the lamp/alarm output control setting finished. (factory set 0)

# Anhui Risesat Electronics Co., LTD

## 8. To set lock time:

When digital display indicate Pb, the gate opener is on lock time control setting. The lock control time means the time we could control the lock. There is 0-2 for optional. "0" means the lock control time is 1s, "1" means the lock control time is 1.5s, "2" means the lock control time is 2s. Each time you press and release the [INC+] button, the figure increase by 1; each time you press and release the [DEC-] button, the figure decrease by 1. Press the [FUN] button to store the data when the lock control time chosen, then the lock time setting finished. (factory set 0)

## 9. To choose single/double gate open:

When digital display indicate PC, the gate opener is on single/double gate open setting. There is 0-3 for optional. "0" means the gate could not open by remote, "1" means just can open one single gate, "2" means can just open two leaf gate, "3" means can open one single gate as well as two leaf gate. Each time you press and release the [INC+] button, the figure increase by 1; each time you press and release the [DEC-] button, the figure decrease by 1. Press the [FUN] button to store the data when the single/double gate open chosen, then the remote button setting finished. (factory set 3)

## 10. To choose photocell work in NC or NO

When digital display indicate Pd, you could choose the photocell work in NO or NC. Value 00 means work in NO, value 01 means work in NC.

## 11. To choose single gate or double gate working mode:

When digital display indicate PE, you could choose the gate working mode for double gates or single gate. For only one gate motor, you should choose the value to be 1; For two gates motor, you should choose the value to be 0. ( factory set 0)

## 12. To reset:

When digital display indicate Po, the gate opener is on rest setting. After enter Po setting, press the [ FUN] to store and then now the reset successfully.